



ACC-MNT-2

Mounting Arm Kit

Wall mounted extender arm with built in 1.5" female NPT thread.

Compatible with: **ACC-MNT-1** and **ACC-MNT-4**.

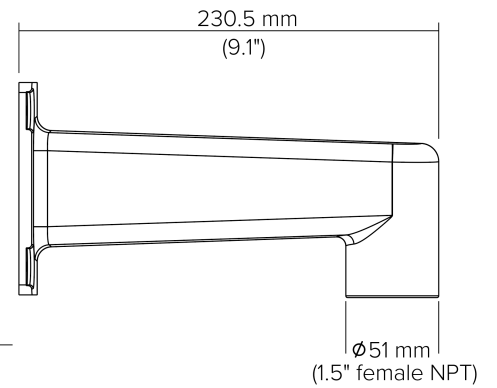
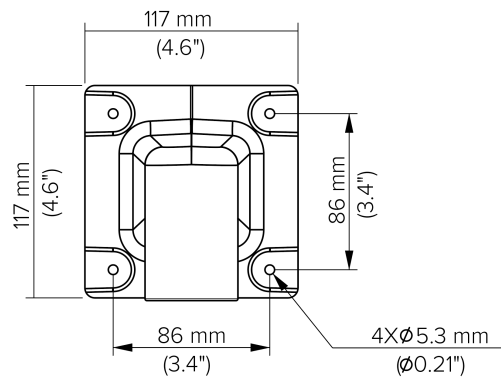

Technical Specifications

Model	ACC-MNT-2	Weight	700g (1.54 lbs)
Material	Aluminum Alloy	Box Dimensions	270x175x134mm (10.6x6.9x5.3")
Dimensions	231x117x117mm (9.1x4.6x4.6")	Box Weight	964g (2.13 lbs)
Color	White		

